

HPS 高壓轉角缸



High Pressure Swing Clamp Cylinder

• Bore: $\phi 25$ - $\phi 63$ mm • Pmax: 500kg/cm²

產品簡介

- 此型式油壓缸適用於夾持工件取放空間需保持靜空，方便工件取放及高壓夾持。
- 油壓缸夾持動作為下壓式，含有旋轉行程(請勿夾持工件)以及垂直下壓行程。
- 缸體內壁經特殊加工處理，表面光滑確保使用性能及壽命。
- 最大充油速度請參考特性資料，請勿使用過大充油速度，以免迴轉過快，如有迴轉不確實，請加裝流量控制閥，降低充油速度。
- 壓板長度及使用壓力請參考附圖所示，請勿任意超長使用。

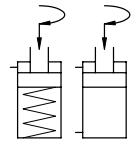

Product Introduction

- The series of swing clamp cylinder is ideal for workpiece clamping which requires a sufficient space for convenient workpiece loading and unloading and high pressure clamping.
- It provides swing motion (do not clamp workpiece) and vertical hold down motion.
- The swing clamp cylinder employs Germany oil seal and imported parts. The inside surface of cylinder barrel is specially treated, featuring maximum smoothness, high performance and long service life.
- For maximum oil feeding speed, refer to specifications. Do not exceed oil feeding speed to avoid too high swing speed. In case improper swing speed occurs, it is suggested to equip with an additional oil flow control valve to reduce oil feeding speed.
- Refer to the comparison diagram between the effective clamping force and working pressure. Do not extend the swing arm length as desired.

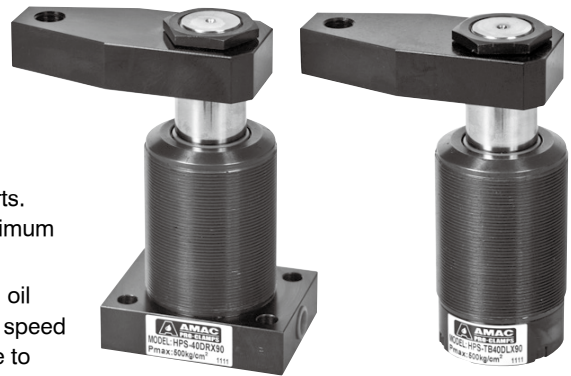

特性資料 Specifications

油缸內徑	Bore of cylinder	mm	$\phi 25$	$\phi 32$	$\phi 40$	$\phi 50$	$\phi 63$
活塞桿徑	Piston rod diameter	mm	$\phi 20$	$\phi 25$	$\phi 32$	$\phi 40$	$\phi 50$
轉角行程	Swing stroke	mm	8	9	9	12	12
垂直行程	Clamping stroke	mm	11	13	13	15	15
最大充油速度	Max. oil filling speed	cm ³ /s	3.3	6.9	9.9	19.1	31.1
下壓需油量	Downward clamping oil required	cm ³	3.3	6.9	9.9	19.1	31.1
回復需油量	Return oil required	cm ³	9.3	17.7	27.6	53	84.2
轉角方向	Rotating direction		R: 順時針右轉 / L: 逆時針左轉 / N: 0° 不旋轉 R: Turn right / L: Turn left / N: 0° No swing				
轉角角度	Rotating angle		標準角度 90° 選擇角度 45°, 60° Standard angle 90°, Optional angle 45°, 60°				
最小操作壓力	Min operation pressure	D 雙動 Double-acting	10 kg/cm ²				
		S 單動 Single-acting	40 kg/cm ²				

訂購標示法 Ordering Code

HPS - M 25 D R × 90

↑ ↑ ↑ ↑ ↑ ↑

① ② ③ ④ ⑤ ⑥

①	系列別 Series	HPS	
②	安裝型式 Mounting type	底座型 Flange	空白Blank: 配管型 Line type
			M: 油路板型 Manifold type
		全身型	TB: Threaded body
③	油缸內徑 Bore of cylinder	$\phi 25$, $\phi 32$, $\phi 40$, $\phi 50$, $\phi 63$	
④	作動方式 Acting type	單動 S: Single-acting	
		雙動 D: Double-acting	
⑤	轉角方向 Rotating direction	R: 順時針右轉 / L: 逆時針左轉 / N: 0° 不旋轉 R: Turn right / L: Turn left / N: 0° No swing	
⑥	轉角角度 Rotating angle	90: 90° / 45: 45° / 60: 60°	

HPS 高壓轉角缸



High Pressure Swing Clamp Cylinder

• Bore:ø25-ø63mm • Pmax:500kg/cm²

有效夾持力FSP與操作壓力P對照圖

Comparison diagram between the effective clamping force
FSP and working pressure P

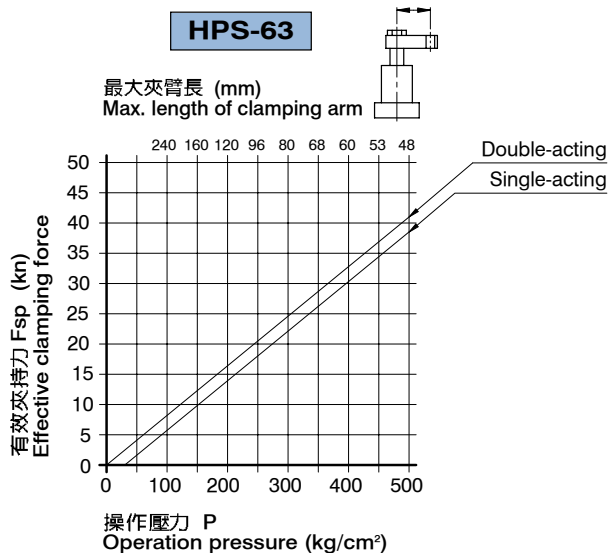
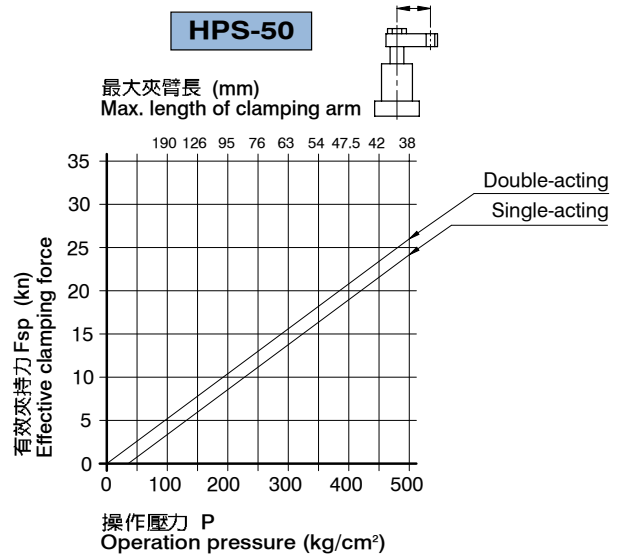
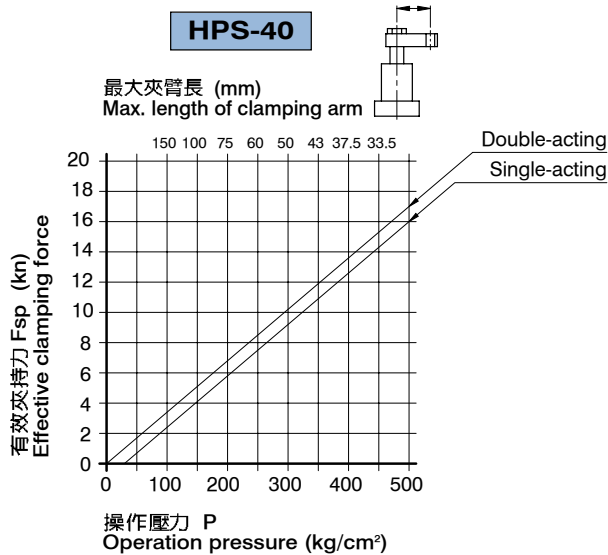
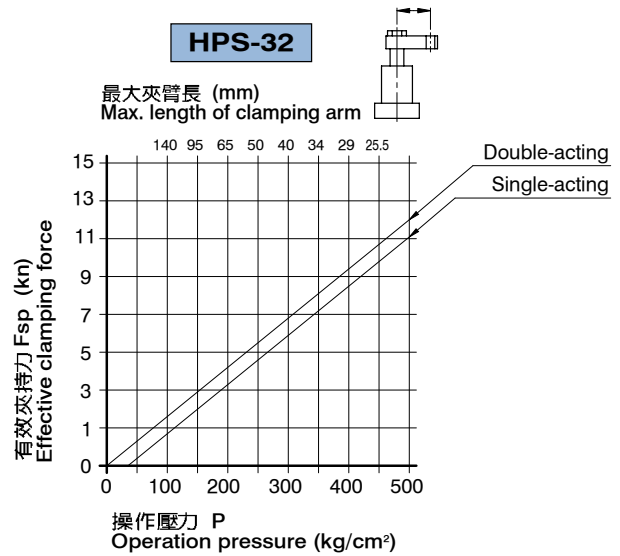
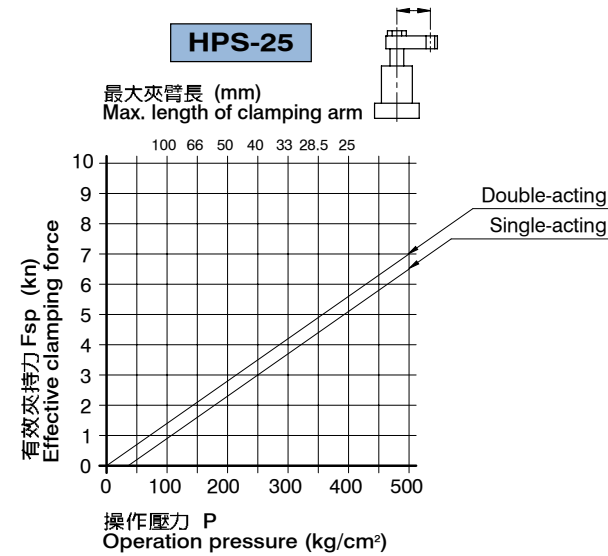

HPS 高壓轉角缸



High Pressure Swing Clamp Cylinder

• Bore: $\phi 25$ - $\phi 63$ mm • Pmax: 500kg/cm²

Single-acting

Double-acting

Threaded Type

Flange Type

Threaded Type

Flange Type

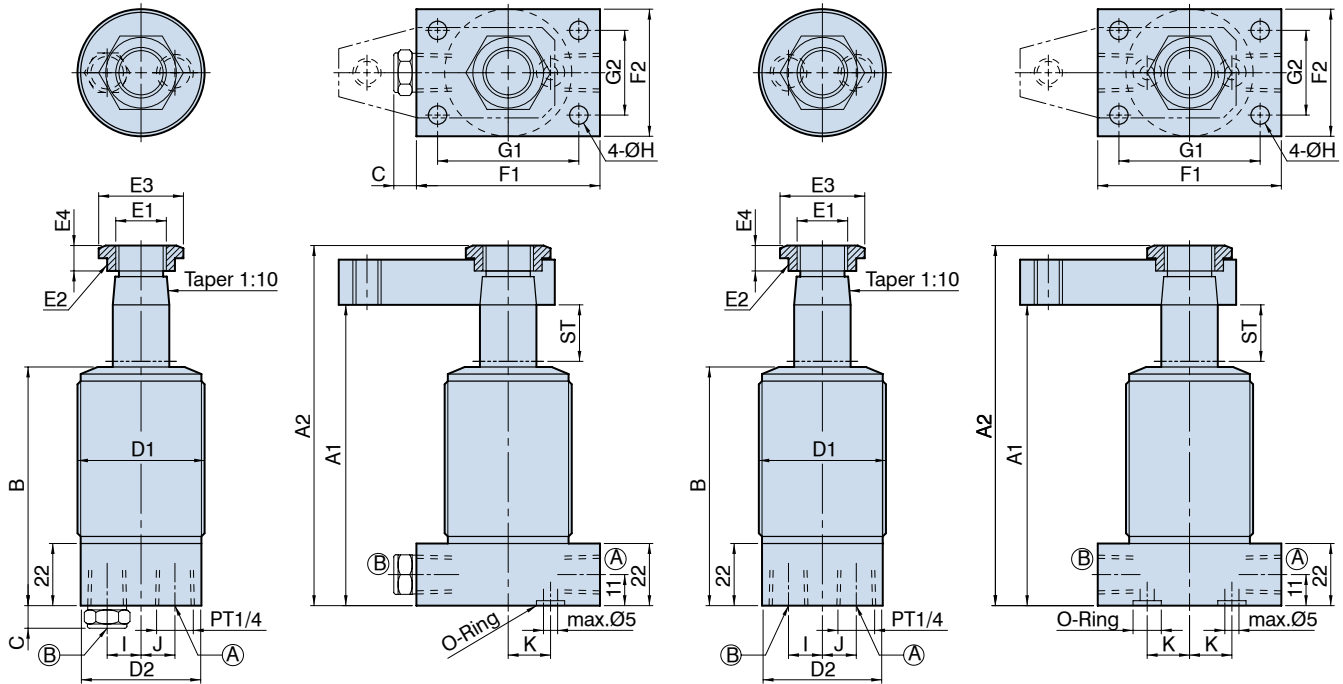

- (A) 夾持油孔
Clamping Port
- (B) 排氣孔
Vent port

- (A) 夾持油孔
Clamping Port
- (B) 放鬆油孔
Unclamping Port

Dimensional table

UNIT:mm

ITEM \ MODEL	HPS-25	HPS-32	HPS-40	HPS-50	HPS-63
ST:SWING / CLAMPING	19:8/11	22:9/13	22:9/13	27:12/15	27:12/15
A1	107.5	120.5	123.5	142	148
A2	129	146.5	152.5	177	190
B	87	97	100	113.5	119.5
C	8	8	8	8	8
D1	M45x1.5	M52x1.5	M60x1.5	(M80x2.0)	(M90x2.0)
D2	$\phi 43$	$\phi 50$	$\phi 58$	$\phi 78$	$\phi 88$
E1	M18x1.5	M22x1.5	M28x1.5	M35x1.5	M43x1.5
E2	$\phi 23.5$	$\phi 28.5$	$\phi 35.5$	$\phi 45.5$	$\phi 54.5$
E3	27.7	33.5	41.6	53.1	63.5
E4	9	10	10	12	14
F1	65	73	85	100	115
F2	45	53	63	80	90
G1	50	57	65	80	90
G2	30	37	44	60	68
H	$\phi 6.8$	$\phi 9$	$\phi 9$	$\phi 13$	$\phi 15$
I	13	14.5	16	(20)	(26)
J	13	16	20	(26)	(33)
K	15	20	28	31	37.5
O-Ring	P7	P7	P7	P9	P9